

**MECHANICAL ENGINEERING Paper I****Time Allowed: Three Hours****Maximum Marks: 200****INSTRUCTIONS**

Please read each of the following instructions carefully before attempting questions.

Candidates should attempt **FIVE** questions in all. Question No, 1 is compulsory.

Out of the remaining **SIX** questions attempt any **FOUR** questions.

The number of marks carried by a part of a question are indicated against it.

Answers must be written in **ENGLISH** only.

Assume suitable data, if necessary, and indicate the same clearly.

For air  $R = 0.287 \text{ kJ/kg-K}$ ,  $C_p = 1.005 \text{ kJ/kg-K}$ ,  $\gamma = 1.4$ ,  $M = 28.97 \text{ kg/kg-mole}$ ,  
Universal gas constant  $R = 8.314 \text{ kJ/kg mole-K}$ .

Unless otherwise mentioned, symbols and notations have their usual standard meanings.

Neat sketches may be drawn, wherever required.

Attempts of questions shall be counted in chronological order. Unless struck off, attempt of a question shall be counted even if attempted partly.

Any page or portion of the page left blank in the answer book must be clearly struck off.

A psychrometric chart is attached to this question paper for necessary use by the candidate.

1. (a)  $0.14 \text{ m}^3$  of steam at 20 bar and  $250^\circ \text{C}$  is expanded reversibly and polytropically to 2 bar. Find the final temperature, work done, heat transferred and change of entropy, if the index of expansion is 1.25.
  - (b) The specific heats of a gas are of the form  $C_p = a + kT$  and  $C_v = b + kT$ , where  $a$ ,  $b$  and  $k$  are constants and  $T$  is in K. Derive the formula  $T^b v^{a-b} e^{kt} = \text{constant}$ , for adiabatic expansion of the gas.
  - (c) A closed system contains  $0.5 \text{ kg}$  of air. It expands from 2 bar,  $60^\circ \text{C}$  to 1 bar,  $40^\circ \text{C}$ . During expansion it receives  $2 \text{ kJ}$  of heat from a reservoir at  $100^\circ \text{C}$ . Assuming atmospheric conditions to be at 0.95 bar and  $30^\circ \text{C}$ , calculate (i) the maximum, work, (ii) work done on atmosphere, and (iii) change in availability.
2. (a) Prove that for the same compression ratio the Otto cycle is more efficient than the Diesel cycle.
  - (b) Sketch and explain the working of a simple carburetor. Also explain how the slow running and compensating jets work.
  - (c) The volume ratios of compression and expansion for a Diesel engine as measured from an indicator diagram are 15.3 and 7.5 respectively. The pressure and temperature at the beginning of compression are 1 bar and  $27^\circ \text{C}$ . Assuming an ideal engine, determine the mean effective pressure, the ratio of maximum pressure to mean effective pressure and the cycle efficiency. Also find the fuel consumption per kWh if the indicated thermal efficiency is 0.5 of ideal efficiency, mechanical efficiency 0.8 and calorific value of oil  $42000 \text{ kJ/kg}$ .
3. (a) What do you understand by nuclear fission? What are the essential requirements to cause nuclear fission? Draw a neat diagram of a nuclear reactor and explain the function of different components.
  - (b) Following observations were made during the trial of a gas fired boiler of steam power plant:

Generator output	50000 kW
Steam conditions	pressure 50 bar, temperature $500^\circ \text{C}$
Feed water temperature	$80^\circ \text{C}$
Steam output	65 kg/s
Percentage composition of fuel (natural gas), by volume	$\text{CH}_4 = 96.5$ , $\text{C}_2\text{H}_6 = 0.5$ (rest incombustibles)
Higher calorific value of gas	$38700 \text{ kJ/m}^3$ at 1.013 bar and $15^\circ \text{C}$
Gas consumption	$6.5 \text{ m}^3/\text{s}$

Calculate the boiler, efficiency and the overall thermal efficiency based on the lower calorific value of the fuel.

4. (a) Mention the types of nozzles you know. Where are these used?  
 (b) From first principles, prove that maximum discharge per unit area in a steam nozzle at the throat is given by the expression

$$\frac{m_{\max}}{A} \left[ n \frac{p_1}{v_1} \left( \frac{2}{n+1} \right)^{\frac{n+1}{n-1}} \right]^{1/2}$$

where  $p_1$  and  $v_1$  are pressure and specific volume at the inlet and  $n$  is the index of expansion.

- (c) At a particular ring of a reaction turbine having 50% degree of reaction, the blade speed is 70 m/s. The mass of steam is 5 kg/s, dry saturated at 1.5 bar. Both fixed and moving blades have inlet and exit angles of  $35^\circ$  and  $20^\circ$  respectively. Determine
- The power developed in kW by the pair of rings,
  - The blade height, which is to be one-tenth the mean blade ring diameter,
  - The heat drop by the pair if the steam expands with an efficiency of 80%.
5. (a) Given the radial equilibrium equation in the form

$$\frac{dp}{dr} = \frac{\rho}{g} \frac{V_t^2}{r}$$

where  $V_t$  is the tangential component of velocity of a gas element of density  $\rho$  at a radius  $r$ , the pressure being  $p$ , derive the free vortex equation, stating clearly the assumptions made.

- (b) A centrifugal compressor has a pressure ratio of 4/1 with an isentropic efficiency of 82% when running at 16000 rpm. It takes in air at  $17^\circ$  C. Guide vanes at inlet give the air a pre-whirl of  $20^\circ$  to the axial direction and radial and the mean diameter of the eye is 200 mm, the absolute air velocity at inlet is 120 m/s. At exit the blades are radially inclined and the impeller tip diameter is 550 mm. Calculate the slip factor of the compressor.
- (c) Describe with a neat sketch the working of a turbojet engine.
6. (a) What is effective temperature? Sketch a comfort chart and explain its significance.  
 (b) The properties of air in a room are temperature  $35^\circ$  C and relative humidity 70 percent. Determine
- the partial pressure of air,
  - the humidity ratio,
  - the saturation ratio,
  - dew point temperature,
  - density of the air-vapour mixture,
  - the enthalpy of mixture per kg of dry air.

Assume room pressure to be 1.0132 bar and the specific heat for the super-heated vapour as 1.863 kJ/kg K. Solve the problem with the help of steam tables.

- (c) A Freon-12 refrigerator producing a cooling effect of 20 kJ/s operates on a simple cycle with pressure limits of 1.509 bar and 9.607 bar. The vapour leaves the evaporator dry saturated and there is no undercooling. Determine the power required by the machine. If the compressor operates at 3000 rpm and has a clearance volume of 3% of stroke volume determine the piston displacement of the compressor.

For compressor assume that the expansion follows the law  $pv^{1.13} = \text{constant}$ .

Temp. °C	$P_s$ bar	$v_g$ m <sup>3</sup> /kg	Enthalpy kJ/kg		Entropy kJ/kg K		Specific heat kJ/kg K
			$h_h$	$h_g$	$s_f$	$s_g$	
-20	1.509	0.1088	17.8	178.61	0.073	0.7082	
40	9.607		74.53	203.05	0.2716	0.682	0.747

7. (a) Derive the equation for temperature distribution in a fin with an insulated tip.

- Then obtain an expression for heat dissipation by integrating the convective losses along its surface.
- (b) Define the terms NTU and effectiveness. Derive an expression for effectiveness of a counter flow heat exchanger in terms of NTU and capacity ratio.
- (c) Show that the heat emitted per unit area from a blackbody in the hemisphere above the body surface is given by  $q_0 = \pi I$ . Where  $I$  is the black body radiation emitted per unit time and solid angle subtended at the source, and per unit area of emitting surface normal to the mean direction in space.
8. (a) Define the terms boundary layer thickness, displacement thickness and the momentum thickness and discuss their practical utility.
- (b) Obtain an expression for the specific speed of a hydraulic turbine and explain its significance. Give the range of specific speed values of the Kaplan, Francis turbines and Pelton wheels.
- (c) A centrifugal pump has an impeller with inner and outer diameter of 150 and 250 mm respectively. The pump delivers  $0.05 \text{ m}^3/\text{s}$  of water when running at 1500 rev/ min. The velocity of flow through the impeller remains constant at 2.5 m/s. The blades are curved back at an angle of  $30^\circ$  to the tangent at exit and the inlet is axial. The diameters of the suction and delivery pipes are 150 mm and 100 mm respectively. The pressure head at suction is 4 m below and that at delivery is 18 m above atmosphere. The power required to drive the pump is 18 kW.
- Find: (i) the vane angle at inlet (ii) the overall efficiency, and (iii) the manometer efficiency.

**MECHANICAL ENGINEERING Paper II****Time Allowed: Three Hours****Maximum Marks: 200****INSTRUCTIONS**

Please read each of the following instructions carefully before attempting questions: Candidate should attempt **FIVE** questions in all. Question No. 1 in Section A is compulsory.

Out of the remaining, attempt **TWO** from Section-B and **TWO** from Section—C.

All questions carry equal marks. The number of marks carried by a part of a question is indicated against it.

Answer must be written in **ENGLISH** only.

Unless other-wise mentioned, symbols and notations have their usual standard meanings.

Neat sketches may be drawn, wherever required.

All parts and sub-parts of a question are to be attempted together in the answer book.

Attempts of questions shall be counted in chronological order. Unless struck off, attempt of a question shall be counted even if attempted partly.

Any page or portion of the page left blank in the answer book must be clearly struck off.

**SECTION—A**

1. Answer all 20 parts of the question each part carries 2 marks.
  - (a) State Grashof's criterion for a movability of a four bar linkage.
  - (b) In an experiment on forced vibration response of a single degree of freedom system, it is found that half power points lie at frequencies 40 and 44 Hz. Find the damping factor of the system.
  - (c) Name any two centrifugal governors, which are gravity controlled. State which one is more sensitive.
  - (d) In reference to a cam-follower mechanism, define
    - (i) Prime circle . (ii) Pressure angle.
  - (e) The elastic and shear moduli of an elastic material are respectively  $2 \times 10^{11}$  Pa and  $8 \times 10^{10}$  Pa respectively. Determine Poisson's ratio of the material.
  - (f) A uniform beam of length L is carrying a uniformly distributed load w per unit length and is simply supported at its ends. What would be the maximum bending moment and where does it occur?
  - (g) Euler's critical load for a column with both ends hinged is found as 40 kN. What would be the change in critical load, if its both ends are fixed?
  - (h) A thin cylindrical vessel of internal diameter d and thickness t is closed at both ends and is subjected to an internal pressure p. How much would be the hoop and longitudinal stress in the material?
  - (i) A power screw has a helix angle  $\alpha$  and coefficient of friction  $\mu$ . Express the condition to be satisfied by the screw to be self locking.
  - (j) State the modes of loading on a steel key connecting a belt driven pulley to shaft.
  - (k) What are the main constituting elements of brass and phosphorus bronze?
  - (l) Group the following materials into thermoplastics and thermosets PVC, Bakelite, Teflon, Formica.
  - (m) How much surface roughness is denoted by the following?

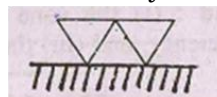

- (n) Name the form of welds, which are represented symbolically as



- (o) In a turning operation determine the material removal rate, if depth of cut = 2 mm, feed per revolution = 0.5 mm and the surface velocity of the job piece = 50 m/minute.
- (p) Name any two advantages, which a hot working process has over the cold working process.

- (q) List any two advantages of Rowan plan of wage incentive for direct workers.
- (r) In a PERT analysis, the critical path of a project is of 120 day with a variance of  $16(\text{days})^2$ . Determine the 95% confidence limits of the project completion time.
- (s) There are two car manufacturing factories A and B, producing same model of cars. They are employing 1200 and 3000 workers and producing 15 and 50 cars per month respectively. Find about productivity of each firm.
- (t) What is a compiler in a computer?

### SECTION—B

2. (a) A solid shaft of diameter 3 cm is fixed at one end. It is subjected to a tensile force of 10 kN and a torque of 60Nm. At a point on the surface of the shaft, determine the principal stresses and the maximum shearing stress. 15
- (b) The equation of the turning moment for a three crank engine is  $T_e = 25.0 - 7.5 \sin 3\theta$  kN-m, where  $\theta$  is the crank angle measured from inner dead centre. The resisting torque exerted by the driven machine is given by  $T_r = 25.0 + 3.6 \sin \theta$  kN m. The moment of inertia of the flywheel is  $360 \text{ kg m}^2$  and the mean engine speed is 450 rpm. Calculate
- power of the engine
  - maximum fluctuation of flywheel energy per cycle, and
  - the coefficient of fluctuation of speed. 25
3. (a) The link of a mechanism is subjected to axial compressive force. It has solid circular cross-section with diameter 9 mm and length 200 mm. The two ends of the link are hinged. It is made of steel having yield strength =  $400 \text{ kN/mm}^2$  and elastic modulus =  $200 \text{ kN/mm}^2$ . Calculate the critical load that the link can carry. Use Johnson's equation. 16
- (b) An automotive single-plate clutch consists of a pair of contacting surfaces. The inner and outer diameters of friction plate are 120 mm and 250 mm respectively. The coefficient of friction is 0.25 and the total axial force is 15 kN. Calculate the power transmitting capacity of the clutch plate at 500 rpm using
- uniform wear theory and
  - uniform pressure theory. 24
4. (a) An epicyclic gear train as shown in Fig. 1 has a sun wheel S of 30 teeth and two planet wheels P-P of 45 teeth. The planet wheels mesh with the internal teeth of a fixed annulus A. The driving shaft carrying the sun wheel transmits 4 kW at 360 rpm. The driven shaft is connected to an arm, which carries the planet wheels. Determine the speed of the driven shaft and the torque transmitted, if the overall efficiency is 95%.

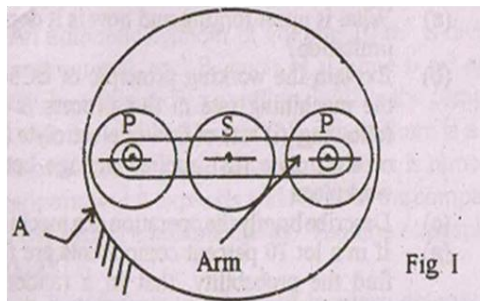

16

- (b) A transmission shaft supporting two pulleys A and B are mounted between two bearings  $C_1$  and  $C_2$  as shown in Fig. 2. Power is transmitted from pulley A to B. The shaft is made of plain carbon steel having ultimate tensile strength =  $600 \text{ N/mm}^2$  and yield strength =  $380 \text{ N/mm}^2$ . Determine the shaft diameter on the basis of torsional rigidity, if the permissible angle of twist between two pulleys is  $0.5^\circ$  and the shear modulus of the material is  $80 \text{ kN/mm}^2$ . The permissible shear stress may taken as 30% of the yield strength or 18% of the ultimate tensile strength, whichever is minimum. Check for its safety.



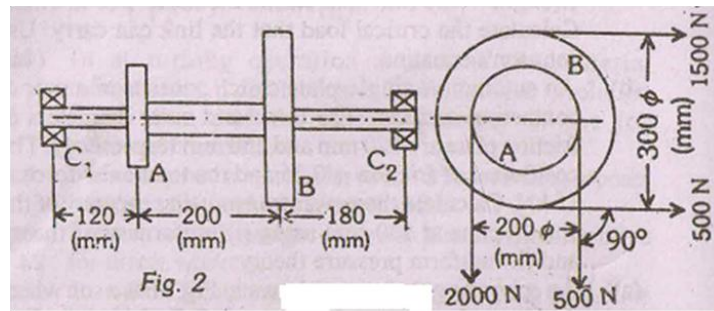

24

## SECTION—C

5. (a) Discuss the factors, which govern the selection of a material for a machine component. 13  
 (b) Describe briefly different stages of tempering process in steels. 12  
 (c) What are the principal uses of (i) low carbon (ii) medium carbon and (iii) high carbon steels? Mention also the amount of carbon present in these steels. 15
6. (a) What is upset forging and how is it done? What are its limitation? 10  
 (b) Explain the working principle of ECM. Discuss how the machining rate in this process is affected by the following: (i) rate of flow of electrolyte (ii) temperature of electrolyte (iii) applied voltage between tool and workpiece. 20  
 (c) Describe briefly the operation of a machining centre. 10
7. (a) If in a lot 10 percent components are found defective, find the probability, that in a random sample of  $S$  components not more than one is defective. 12  
 (b) Describe clearly the function of routing, scheduling and dispatching. 12  
 (c) What is ABC analysis? Describe briefly the procedural steps taken in this analysis. 16